

SPECIFICATION	CONNECTION		
	UNIPOLAR	BIPOLAR (SERIAL)	BIPOLAR (PARALLEL)
AMPS/PHASE	2.80	2.00	4.00
RESISTANCE/PHASE(Ohms)@25°C	1.40±10%	2.80±10%	0.70±10%
INDUCTANCE/PHASE(mH)@1KHz	3.00±20%	12.00±20%	3.00±20%
HOLDING TORQUE(Nm)[lb-in]	2.48[21.97]	3.40[30.12]	3.40[30.12]
STEP ANGLE(°)	1.80		
STEP ACCURACY(NON-ACCUM)	±5.00%		
ROTOR INERTIA(g-cm²)	980.00		
WEIGHT(Kg)[lb]	—		
TEMPERATURE RISE:MAX.80°C (MOTOR STANDSTILL;FOR 2PHASE ENERGIZED)			
AMBIENT TEMPERATURE -10°C~50°C[14°F~122°F]			
INSULATION RESISTANCE 100 Mohm (UNDER NORMAL TEMPERATURE AND HUMIDITY)			
INSULATION CLASS B 130°C[266°F]			
DIELECTRIC STRENGTH 500VAC FOR 1MIN.(BETWEEN THE MOTOR COILS AND THE MOTOR CASE)			
AMBIENT HUMIDITY MAX.85%(NO CONDENSATION)			

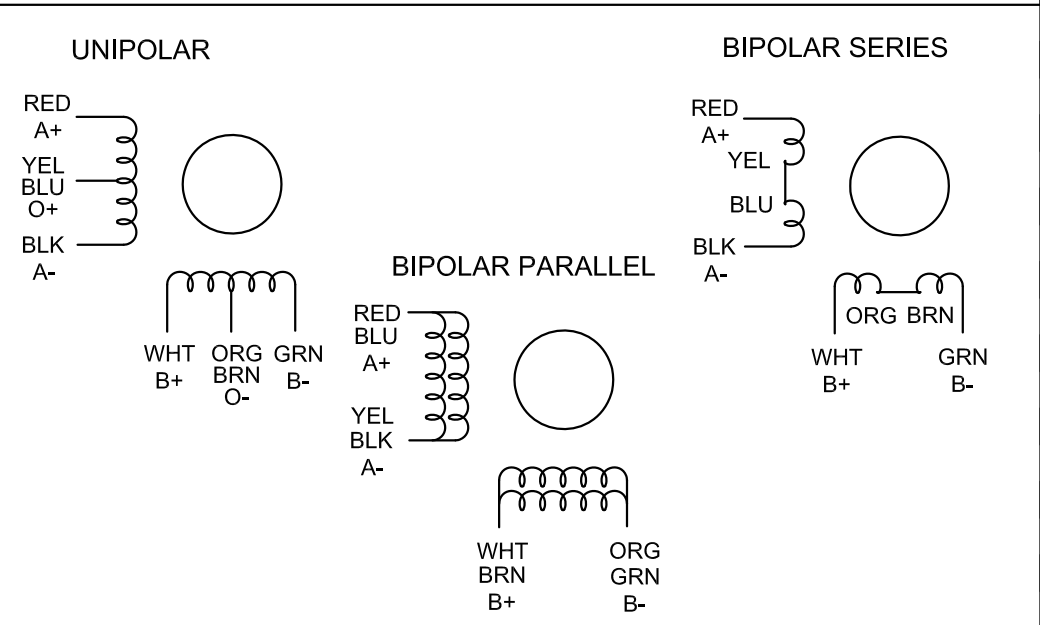

APVD		10.30.2020
CHKD		
1:1.5	DRN	
SCALE	SIGNATURE	DATE

**STEPPER MOTOR**

**24HS39-3008D**