

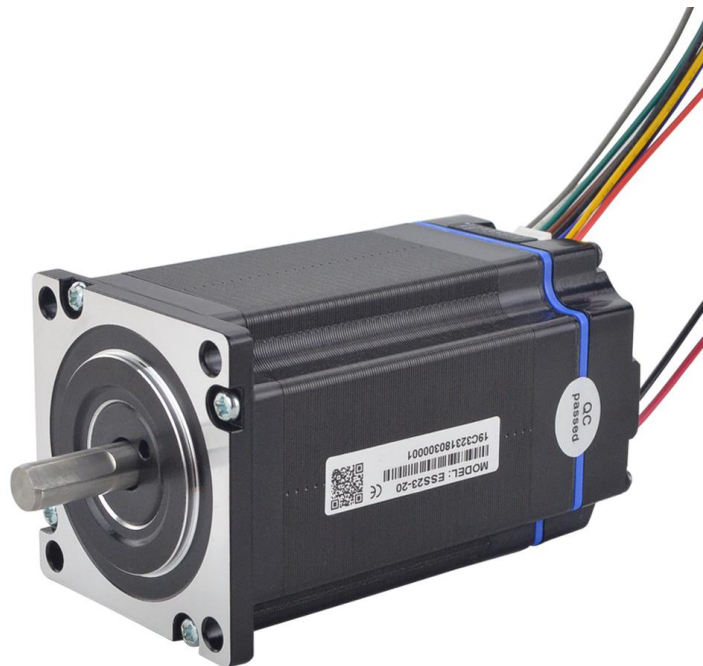

User's Manual
For
ESS23-10 / ESS23-20
Integrated Stepper Motor

©2020 All Rights Reserved Attention: Please read this manual carefully before using the Motor!



ESS23-10 / ESS23-20

Integrated Stepper Motor

Features

- Using a new 32-bit motor control, dedicated DSP chip
- Voltage range: DC24V ~ 50V
- 16 selectable microstep solutions
- Pulse input frequency up to 200 KHz
- Small torque attenuation, speed up to 3000 RPM
- Built-in alarm output, for monitoring and controlling
- Intelligently adjust current, reduce vibration, noise and this can increase efficiency by 35%
- Excellent high speed performance and rigidity, combined with advantages of servo motor and stepper motor

Input signal waveform sequence diagram

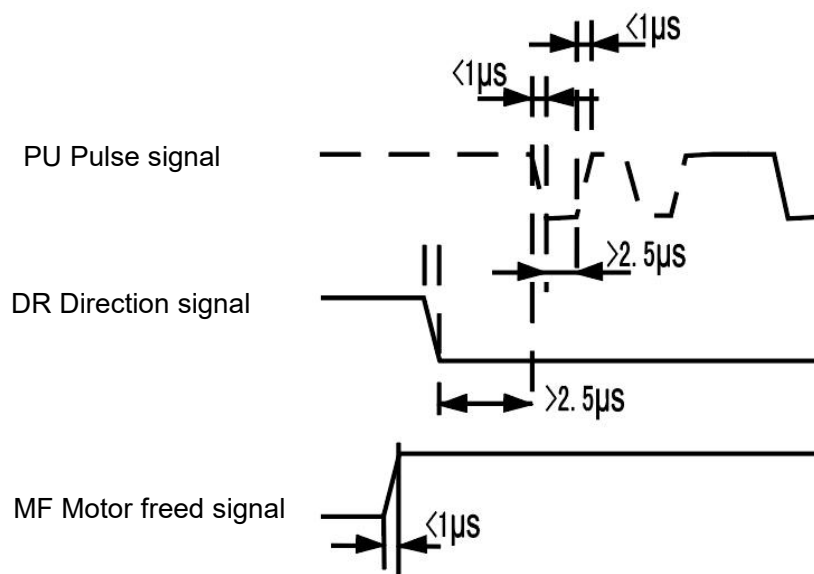

Installation size (unit: mm)

Front view

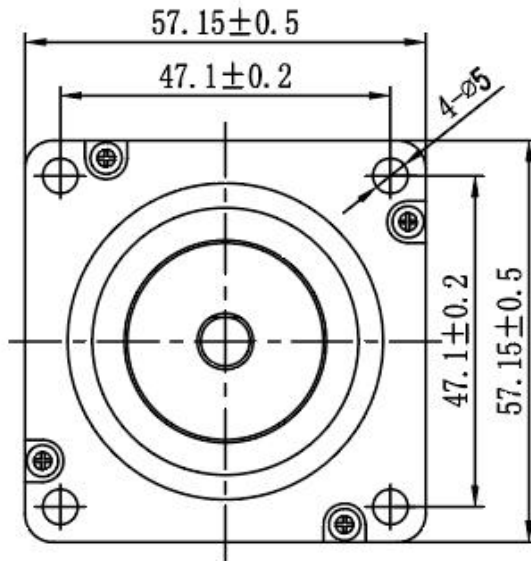

Side view

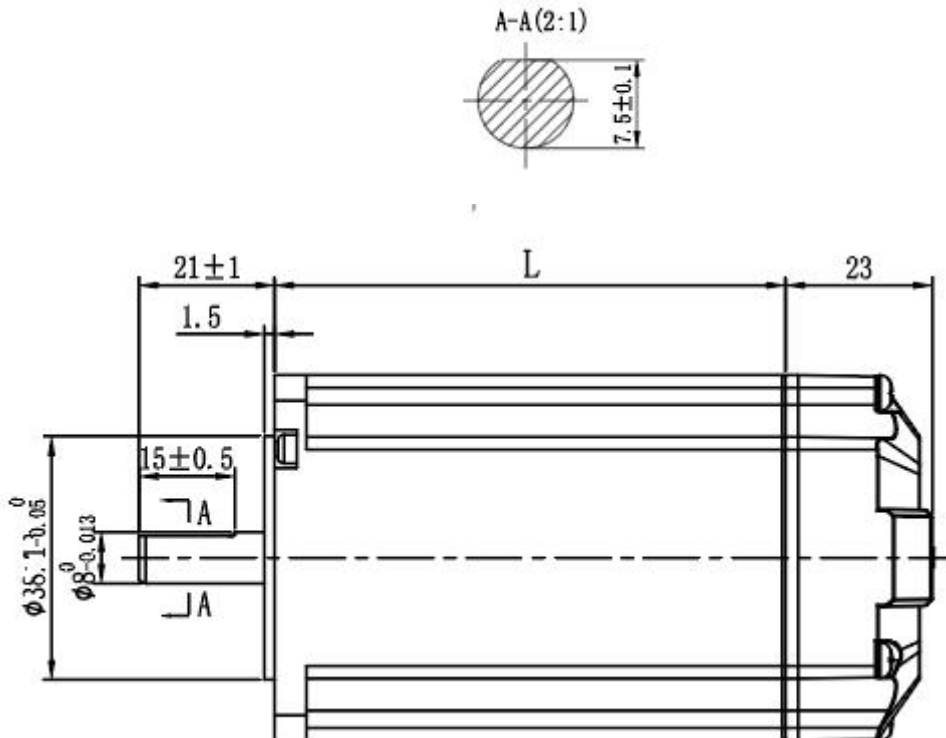

Input/output ports

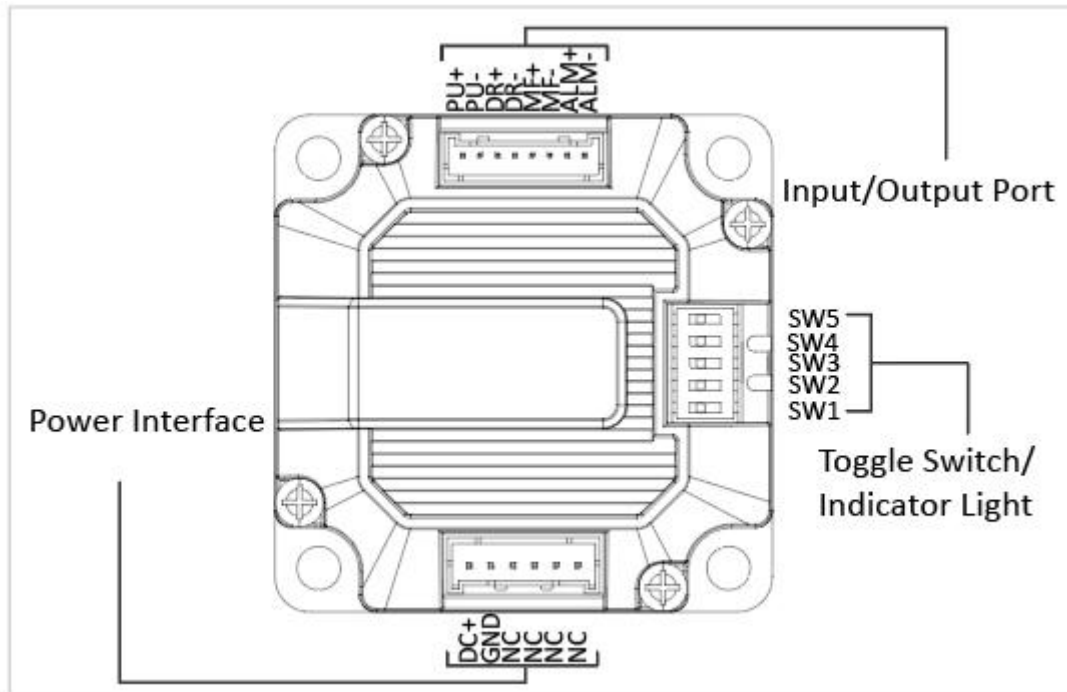

Function	Specification	Remark
VDC+	Supply voltage	VDC: 24 ~ 50V
GND	Ground	
PU+	Pulse input signal+	Signal power supply: 5V ~ 24V, >5V, add a current-limiting resistance
PU-	Pulse input signal-	
DR+	Direction input signal+	
DR-	Direction input signal-	
MF+	Motor freed signal+	
MF-	Motor freed signal-	
ALM+	Alarm output signal+	Over-current, over-voltage, position following error alarm output. The maximum driving current is 50mA
ALM-	Alarm output signal-	
-	NC	NC

Toggle Switch description

PU/Rev	SW2	SW3	SW4	SW5
400	ON	ON	ON	ON
800	OFF	ON	ON	ON
1600	ON	OFF	ON	ON
3200	OFF	OFF	ON	ON
6400	ON	ON	OFF	ON
12800	OFF	ON	OFF	ON
25600	ON	OFF	OFF	ON
51200	OFF	OFF	OFF	ON
1000	ON	ON	ON	OFF
2000	OFF	ON	ON	OFF
4000	ON	OFF	ON	OFF
5000	OFF	OFF	ON	OFF
8000	ON	ON	OFF	OFF
10000	OFF	ON	OFF	OFF
20000	ON	OFF	OFF	OFF
40000	OFF	OFF	OFF	OFF

SW1: Motor rotation direction OFF=CW , ON=CCW





Electrical Specifications

Parameters	ESS23-10 / ESS23-20			
	MIN	TYP	MAX	UNIT
Output Current	1.8	-	4.0	A
Input Voltage	24	36	50	Vdc
Logic Signal Current	7	10	16	mA
Logic Signal Voltage	-	5	24	V
Pulse Input Frequency	0	-	200	kHz
Isolation Resistance	100	-	-	MΩ

Others Specifications

Parameters	UNIT	ESS23-10	ESS23-20
NO. of Phase	--	2	2
Step Angle	°	1.8	1.8
Motor length	mm	56	80
Holding Torque	N.m	1.2	2.2
Rated Current	A	4.0	5.0
Resistance/Phase	Ω	0.43	0.40
Inductance/Phase	mH	1.8	2.0
Rotor Inertia	g.cm ²	280	520
Weight	Kg	0.8	1.2
Insulation Class	--	B	
Operating Temperature	°c	0 ~ 55	

Fault diagnosis

Fault code	Fault Information	RUN/ALM Output	Reset
Err1:0x01	Over-current / short circuit		Power down reset
Err2:0x02	Over-voltage		Lock machine /auto recoery
Err3:0x03	Under-voltage		Lock machine /auto recoery
Err5:0x05	position following error		Power down reset

Operating Environment

Cooling	Natural cooling	
Working Environment	Workplace	Stay away from other heating sources, Avoid dust, oil fog , corrosive and combustibile gases and Strong vibration site
	Temperature	0°C ~ 50°C
	Humidity	40-90%RH(no condensation, no frosting)
	Vibration	10 ~55Hz/0.15mm
Storage Temperature	-20°C ~ +80°C	
Warning: Motor installation, do not knock motor back cover, so as to avoid damage encoder.		

Control signal connection(Input singal)

+5V: R1=0, R2=0

+12V: R1=510Ω, R2=820Ω

+24V:R1=1.2KΩ,R2=1.8KΩ

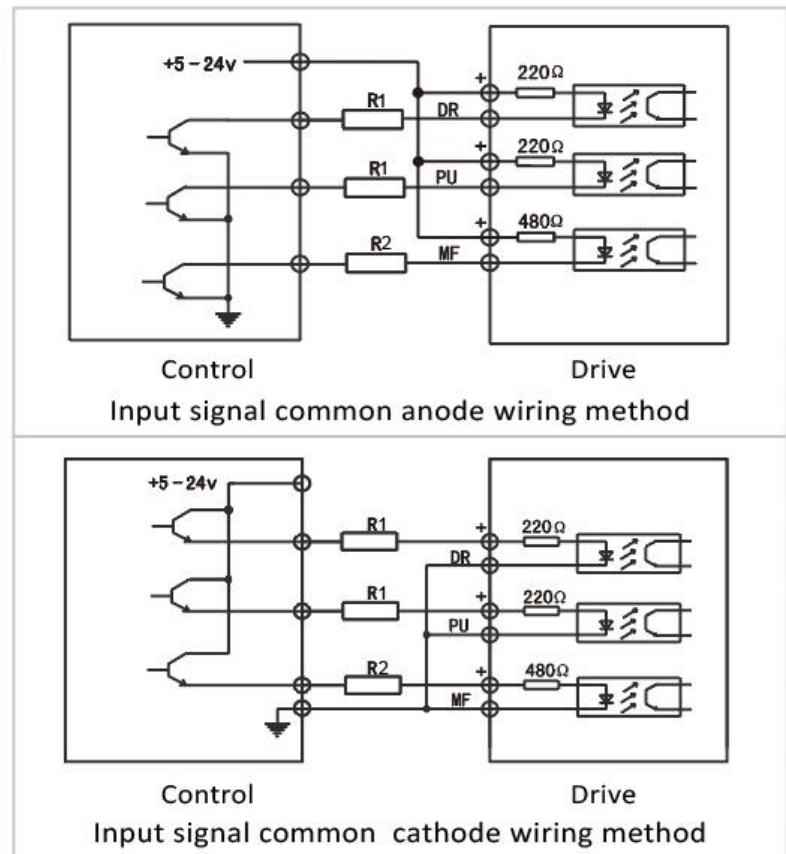

Control signal connection(Output singal)

