

SPEED - TORQUE CURVE

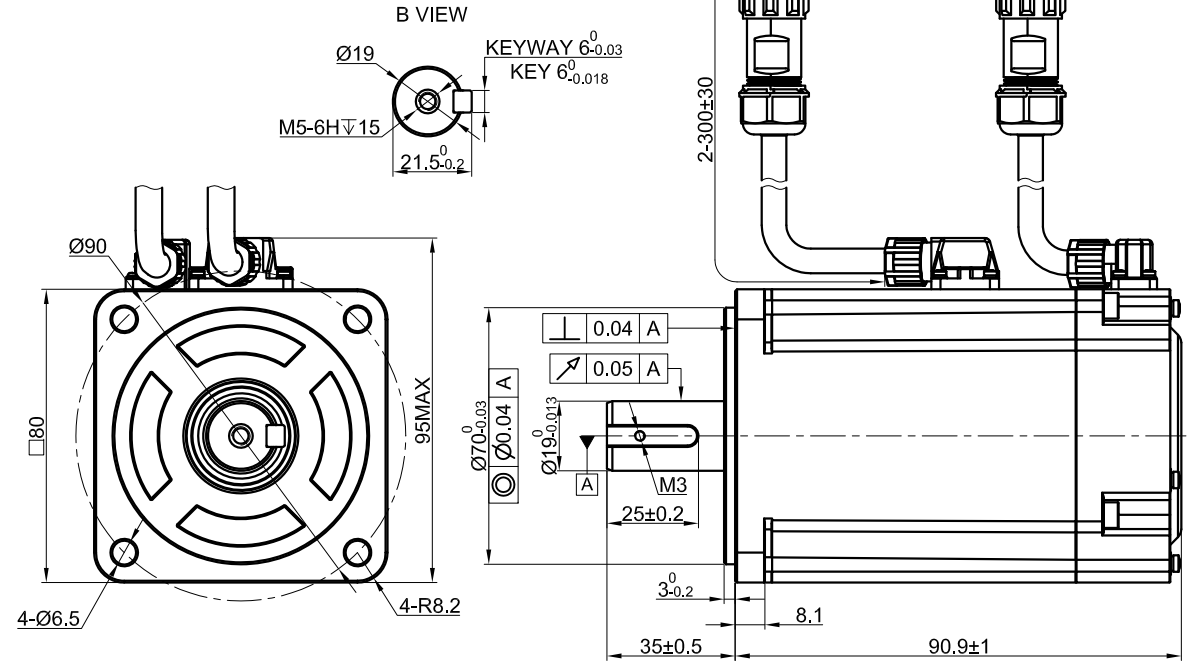
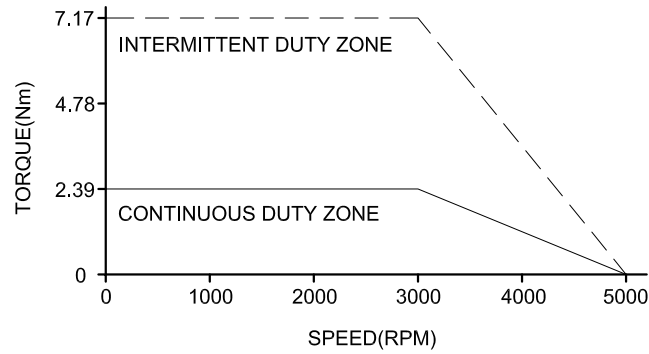

SPECIFICATION	VALUE
RATED VOLTAGE(VAC)	220
RATED POWER(W)	750
RATED TORQUE(Nm)	2.39
PEAK TORQUE(Nm)	7.17
RATED SPEED(RPM)	3000
PEAK SPEED(RPM)	5000
RATED CURRENT(Amp)	4.1
PEAK CURRENT(Amp)	13.4
TORQUE CONST(Nm/Amp)	0.645
BACK EMF CONST(V/KRPM)	39
RESISTANCE(Ω)	1.7
INDUCTANCE(mH)	8
INERTIA(Kg \cdot m 2 \cdot 10 $^{-4}$)	1.5
POLES	10
ENCODER TYPE	17bit inc
IP RATING	IP65
WEIGHT(KG)	2.12

D	WIRING DETAILS OF POWER CABLE CONNECTOR						
		PIN No.	1	2	3	4	—
	DESCRIPTION	U	W	V	PE	—	—
	COLOR	BLU	RED	BLK	YEL/GRE	—	—

C	WIRING DETAILS OF ENCODER CABLE CONNECTOR							
		PIN No.	1	2	3	4	5	6
	DESCRIPTION	PE	5V	0V	SD+	SD-	—	—
	COLOR	SHIELD	WHT	BLK	BLU	PUL	—	—

THE PART NUMBER OF CABLE FOR T6M80-750H2A3-M17S MOTOR		
POWER CABLE	CMST1M5	AWG 18
ENCODER CABLE	CEST1M5	AWG 26



	APVD		4.7.2023
	CHKD		
2:1	DRN		
SCALE	SIGNATURE		DATE

AC SERVO MOTOR
T6M80-750H2A3-M17S