

GM48-3530

48mm gearbox plus 3530 permanent magnet DC motor

Module	0.3/0.4	
Rated torque (kg.cm)	5.0 kg.cm max	
Max momentary tolerance torque (kg.cm)	10.0 kg.cm max	
Reduction ratio	1/89、1/128、1/225 1/250、1/283	1/360、1/400、1/453
Number of gear stages	4	5
Gearbox length L (mm)	12.5	

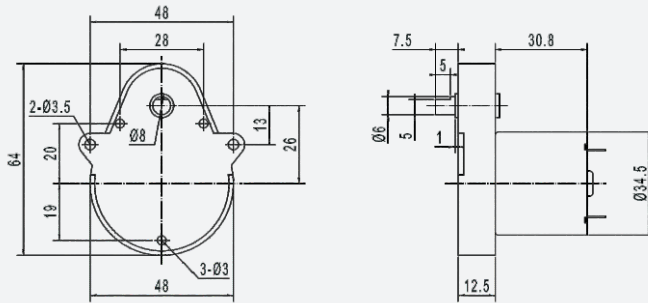
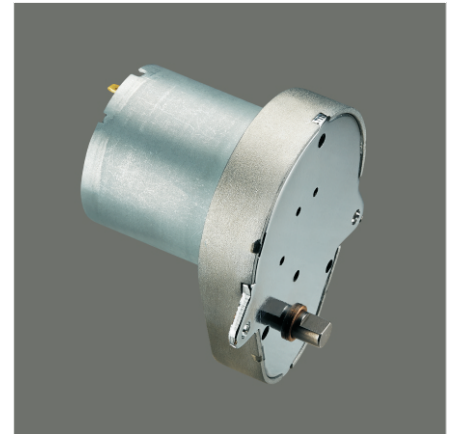

Weight: 190g(Approx)

Unit(mm)

Gear Motor Technical Data

Voltage	Reduction ratio	89	128	225	250	283	360	400	453
		12.0V	No-load speed(rpm)	55	38	22	20	18	14
	Rated speed(rpm)	45	33	19	17	15	12	11	10
	Rated torque(kg.cm)	2.1	3.1	5.0	5.0	5.0	5.0	5.0	5.0
24.0V	No-load speed(rpm)	60	43	24	22	20	16	14	12
	Rated speed(rpm)	55	38	22	20	17	14	12	11
	Rated torque(kg.cm)	2.1	3.1	5.0	5.0	5.0	5.0	5.0	5.0

Motor Technical Data

Motor model	Rated voltage	No-load		Rated			Stall		
		Speed	Current	Speed	Torque	Current	Power	Torque	Current
	VDC	r/min	mA	r/min	g.cm	mA	W	g.cm	A
TRK-3530-1250	12.0	5000	45	4300	40	320	1.8	250	2.0
TRK-3530-2456	24.0	5600	20	4850	40	180	2.0	300	1.2

