

GM25-370CA

25mm gearbox plus 370 permanent magnet DC motor

Module	0.4						
Rated torque (kg.cm)	3.0 kg.cm max						
Max momentary tolerance torque (kg.cm)	6.0 kg.cm max						
Reduction ratio	1/4.2 1/4.4	1/9.3 1/10	1/20 1/21	1/34 1/45 1/47	1/75 1/78 1/99 1/103	1/130 1/165 1/172 1/217 1/227	1/362 1/378 1/478 1/499
Number of gear stages	2	3	4	5	6	7	8
Gearbox length L (mm)	17	19	21	23	25	27	

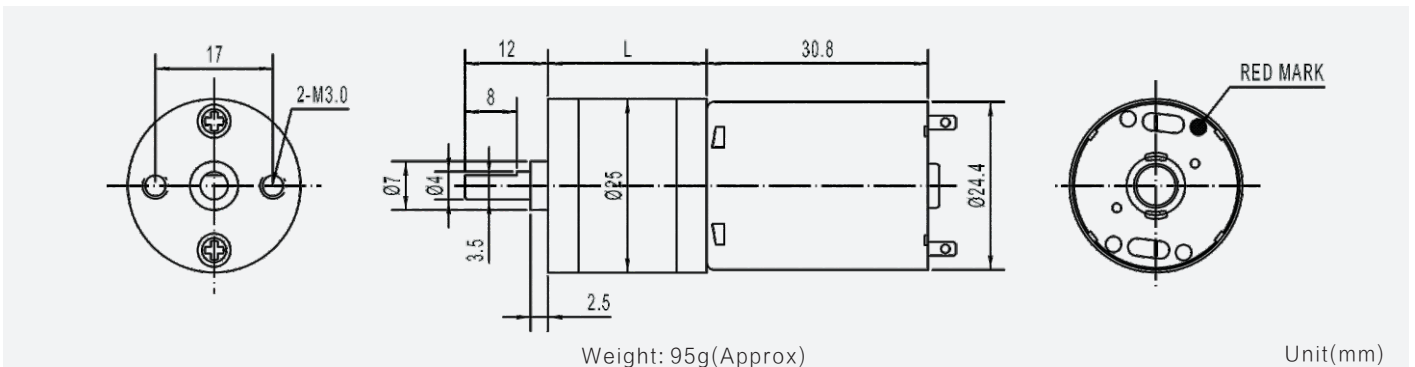

Gear Motor Technical Data

Reduction ratio		4	10	21	34	47	78	103	130	227	499
6.0V	No-load speed(rpm)	1350	550	260	160	115	70	52	42	24	11
	Rated speed(rpm)	1212	485	230	140	102	60	47	36	20	10
	Rated torque(kg.cm)	0.08	0.17	0.4	0.6	0.8	1.2	1.6	2.0	3.0	3.0
12.0V	No-load speed(rpm)	1350	550	260	160	115	70	52	42	24	11
	Rated speed(rpm)	1212	485	230	140	102	60	47	36	20	10
	Rated torque(kg.cm)	0.08	0.17	0.4	0.6	0.8	1.2	1.6	2.0	3.0	3.0

Motor Technical Data

Motor model	Rated voltage	No-load		Rated			Stall		
		Speed	Current	Speed	Torque	Current	Power	Torque	Current
	VDC	r/min	mA	r/min	g.cm	mA	W	g.cm	A
TRK-370CA-22170	6.0	5600	50	4870	25	320	1.25	191	2.1
TRK-370CA-15360	12.0	5600	25	4850	25	170	1.24	186	1.1

