

# GM37T-555PM

37mm gearbox plus 555 permanent magnet DC motor

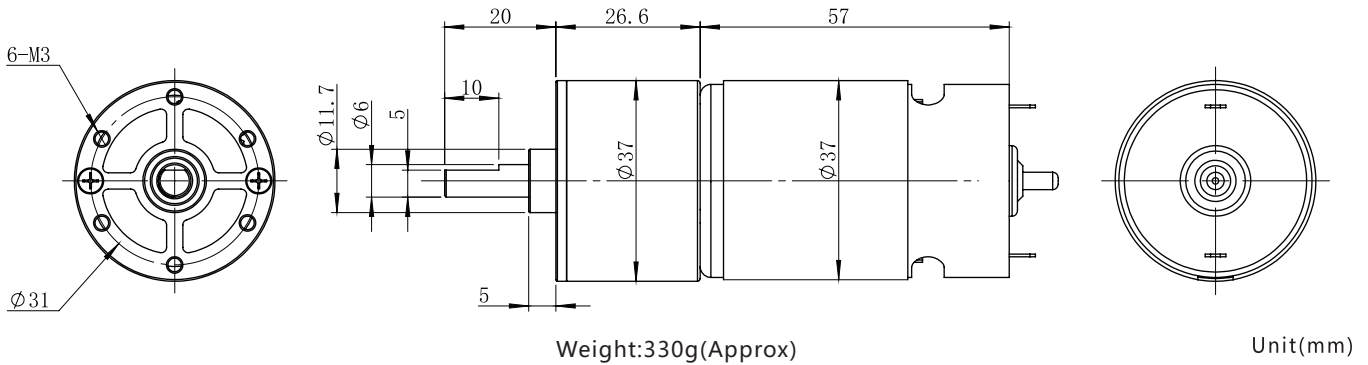

Module	0.5/0.6		
Rated torque (kg.cm)	10kg. cm max		
Max momentary tolerance torque (kg.cm)	20kg. cm max		
Reduction ratio	1/29	1/67	1/202
	1/49	1/98 1/126 1/145	1/294 1/378 1/635
Number of gear stages	4	5	6
Gearbox length L (mm)	26.6		



## Gear Motor Technical Data

Reduction ratio		29	49	67	98	126	145	202	294	378	635
12.0V	No-load speed(rpm)	172	102	75	51	40	34	25	17	13	8
	Rated speed(rpm)	148	88	64	44	34	30	21	15	11	7
	Rated torque(kg.cm)	3.8	6.4	8.0	10	10	10	10	10	10	10
24.0V	No-load speed(rpm)	138	82	60	41	32	28	20	14	11	6
	Rated speed(rpm)	110	65	48	33	25	22	16	11	8	5
	Rated torque(kg.cm)	3.8	6.4	8.0	10	10	10	10	10	10	10

## Motor Technical Data

Motor model	Rated voltage	No-load		Rated				Stall	
		Speed	Current	Speed	Torque	Current	Power	Torque	Current
	VDC	r/min	mA	r/min	g.cm	mA	W	g.cm	A
TRS-555PM-1250	12	5000	250	4300	200	1400	8.8	1430	8.5
TRS-555PM-2440	24	4000	150	3200	200	800	6.6	1000	3.5

