

GMP36-555PM

36mm planetary gearbox plus 555 permanent magnet DC motor

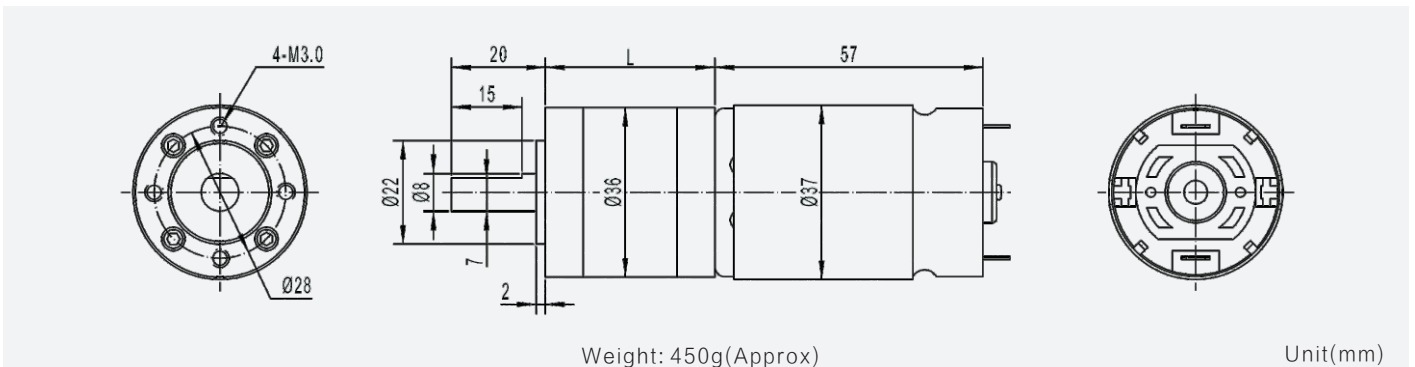

Module	0.5			
Rated torque (kg.cm)	30.0 kg.cm max			
Max momentary tolerance torque (kg.cm)	60.0 kg.cm max			
Reduction ratio	1/4	1/14 1/19 1/27	1/51, 1/71 1/100, 1/139	1/189, 1/264 1/369, 1/516 1/720
Number of gear stages	1	2	3	4
L (mm)	26	33.5	40.5	47.5



Gear Motor Technical Data

Reduction ratio		4	19	51	100	139	189	264	369	516	720
12.0V	No-load speed(rpm)	1200	250	95	48	35	25	19	13	10	7
	Rated speed(rpm)	1100	230	85	45	31	23	16	12	9	6
	Rated torque(kg.cm)	0.6	3.0	6.0	12	15	21	26	30	30	30
24.0V	No-load speed(rpm)	980	200	75	38	28	21	15	10	8	6
	Rated speed(rpm)	750	150	60	30	21	16	13	9	7	5
	Rated torque(kg.cm)	0.6	3.0	6.0	12	15	21	26	30	30	30

Motor Technical Data

Motor model	Rated voltage	No-load		Rated			Stall		
		Speed	Current	Speed	Torque	Current	Power	Torque	Current
	VDC	r/min	mA	r/min	g.cm	mA	W	g.cm	A
TRS-555PM-1250	12.0	5000	250	4400	200	1700	9.0	1640	12.6
TRS-555PM-2440	24.0	4000	150	3150	200	700	6.4	1000	2.7

