

# TEC3625

36mm brushless motor

Connection Mode B	
Clockwise Rotation/Counter Clockwise Rotation	
FG Signal	
PWM Control	
Locked Rotor Protection	
Power	15W(Internal Drive)
	/
Life Expectancy	~3000H(Oil Bearing)
	~5000H(Ball Bearing)

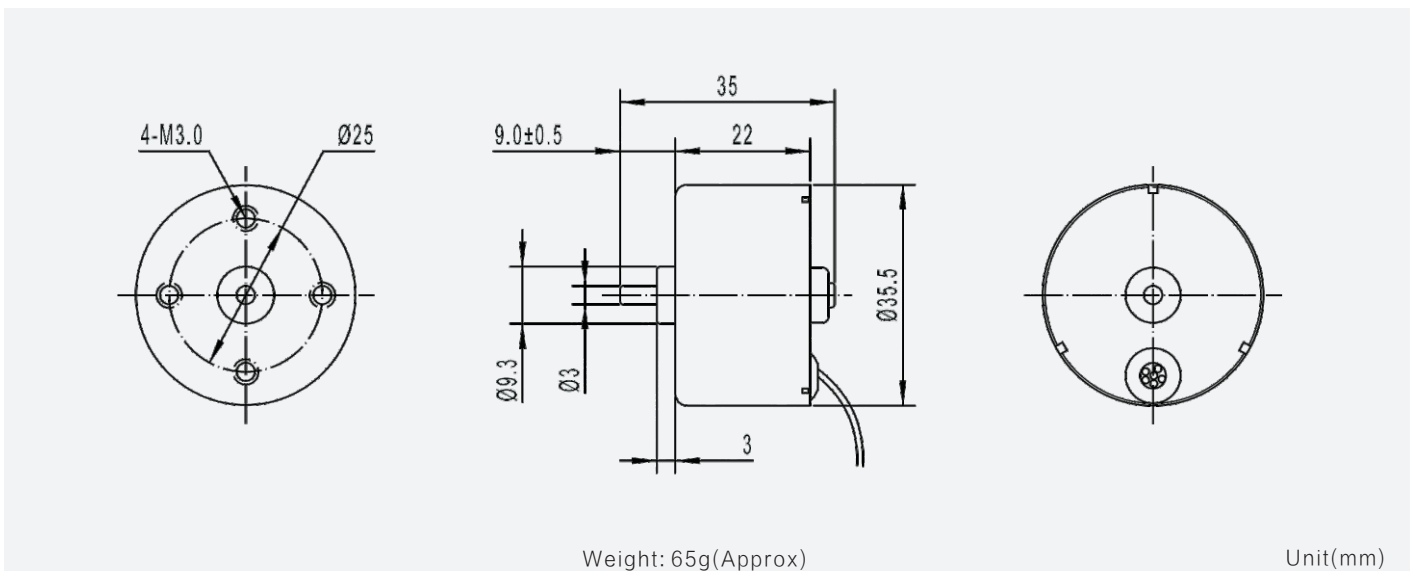

## Motor Technical Data

Motor model	Rated voltage	No-load		Rated				Stall	
		Speed	Current	Speed	Torque	Current	Power	Torque	Current
	VDC	r/min	mA	r/min	g.cm	mA	W	g.cm	A
TEC3625-1245	12.0	4500	90	3650	50	280	1.9	280	1.25
TEC3625-2445	24.0	4500	60	3700	50	160	1.9	310	0.65

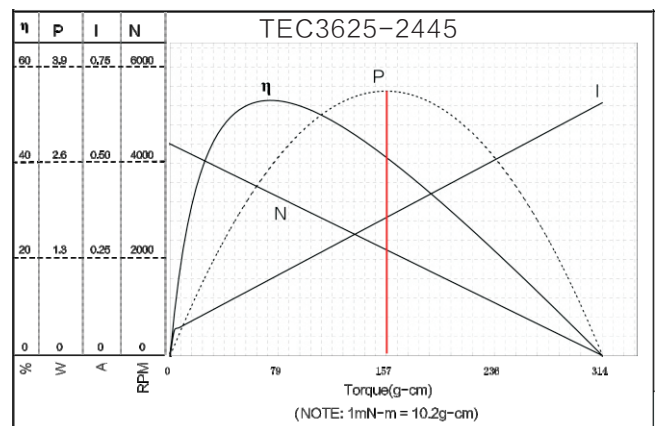
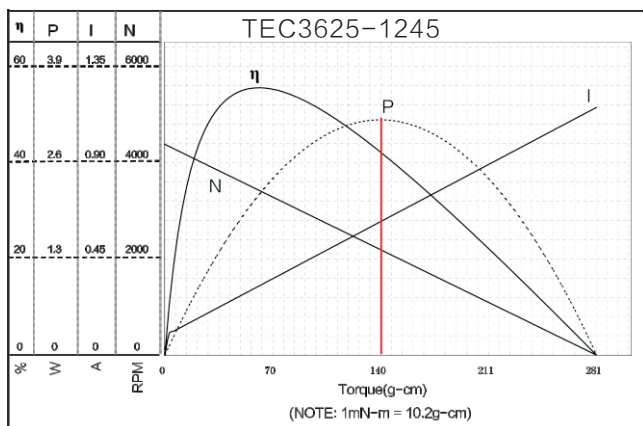

NOTE: the left side of red line area can continuous work