

TWG3246-370CA 32x46mm worm gearbox plus 370 permanent magnet DC motor

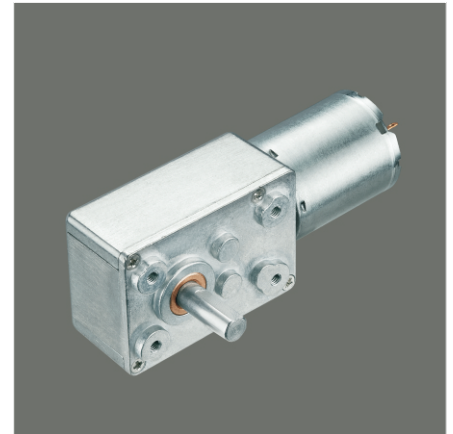

Module	0.5/0.6		
Rated torque (kg.cm)	8.0 kg.cm max		
Max momentary tolerance torque (kg.cm)	15.0 kg.cm max		
Reduction ratio	1/70, 1/146 1/188, 1/233 1/300	1/483, 1/563 1/700, 1/900	1/1020, 1/1313 1/1688, 1/2100 1/2700
Number of gear stages	3	4	5
Gearbox length L (mm)	46.0		

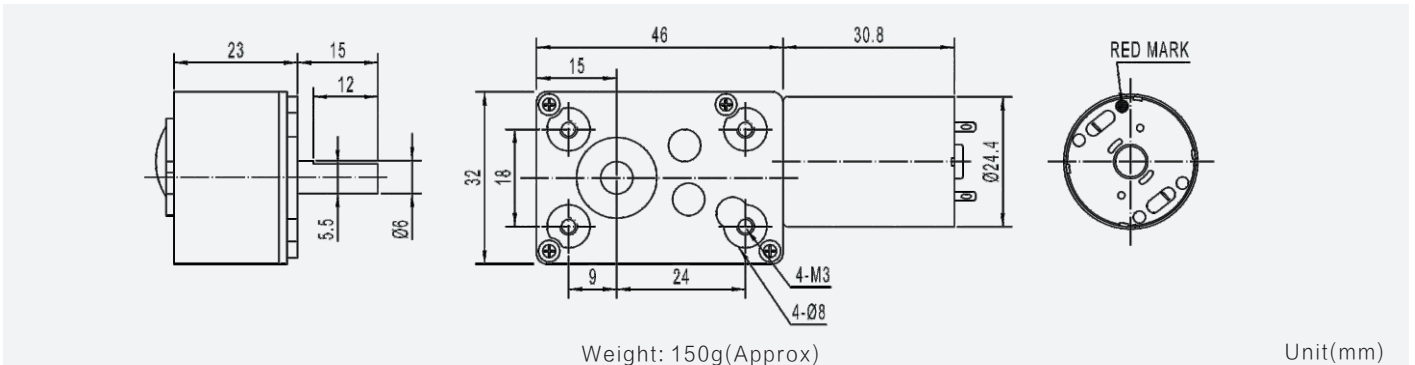

Gear Motor Technical Data

Reduction ratio		146	188	300	438	563	700	900	1020	1313	1688
6.0V	No-load speed(rpm)	38	30	19	12	10	8	6	5	4	3
	Rated speed(rpm)	32	25	16	10	8	6	5	4	3	3
	Rated torque(kg.cm)	2.0	2.5	4.0	5.0	7.0	8.0	8.0	8.0	8.0	8.0
12.0V	No-load speed(rpm)	38	30	19	12	10	8	6	5	4	3
	Rated speed(rpm)	32	25	16	10	8	6	5	4	3	3
	Rated torque(kg.cm)	2.0	2.5	4.0	5.0	7.0	8.0	8.0	8.0	8.0	8.0

Motor Technical Data

Motor model	Rated voltage	No-load		Rated			Stall		
		Speed	Current	Speed	Torque	Current	Power	Torque	Current
	VDC	r/min	mA	r/min	g.cm	mA	W	g.cm	A
TRK-370CA-22170	6.0	5600	50	4870	25	320	1.25	191	2.1
TRK-370CA-15360	12.0	5600	25	4850	25	170	1.24	186	1.1

